

| | |
|---|-------------------------------|
| Subject: PAINT PEELING FROM ARMREST GARNISH | Bulletin No: 09-033/08 |
| | Last Issued: 10/3/2008 |

APPLICABLE MODEL(S)/VINS

2008-2009 CX-9 vehicles with VINs from JM3 TB**** ** 138562 to 166328 (built between November 1, 2007 and July 31, 2008)

DESCRIPTION

Some vehicles may experience the silver paint peeling on the front or rear armrest garnish (A). Chemicals in some hand creams / sun blocks may cause the silver paint to soften. When a metal object such as a watch, key, or bracelet touches the softened paint, the paint may peel away from the surface.

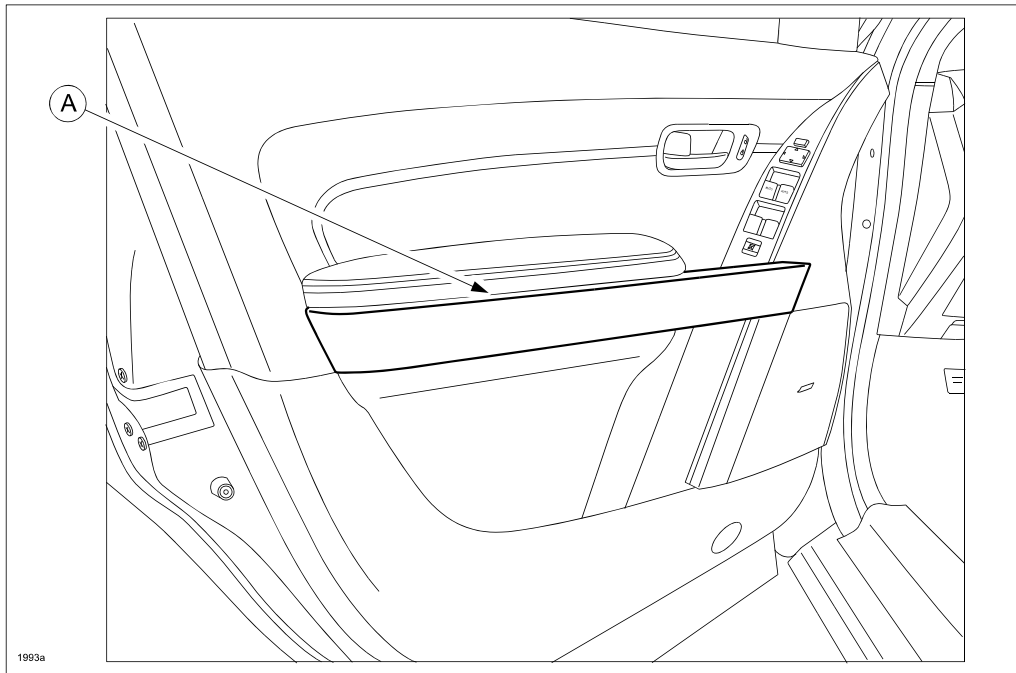

As a mass-production change, the paint has been modified.

Customers having this concern should have their vehicle repaired using the following repair procedure.

REPAIR PROCEDURE

1. Verify customer concern.
2. Replace the armrest garnish with a modified one (front door shown, rear is similar).
 - A. Pull the end of the armrest garnish outward to disengage the clips.
 - B. Pull the armrest garnish rearward to remove from the door trim.

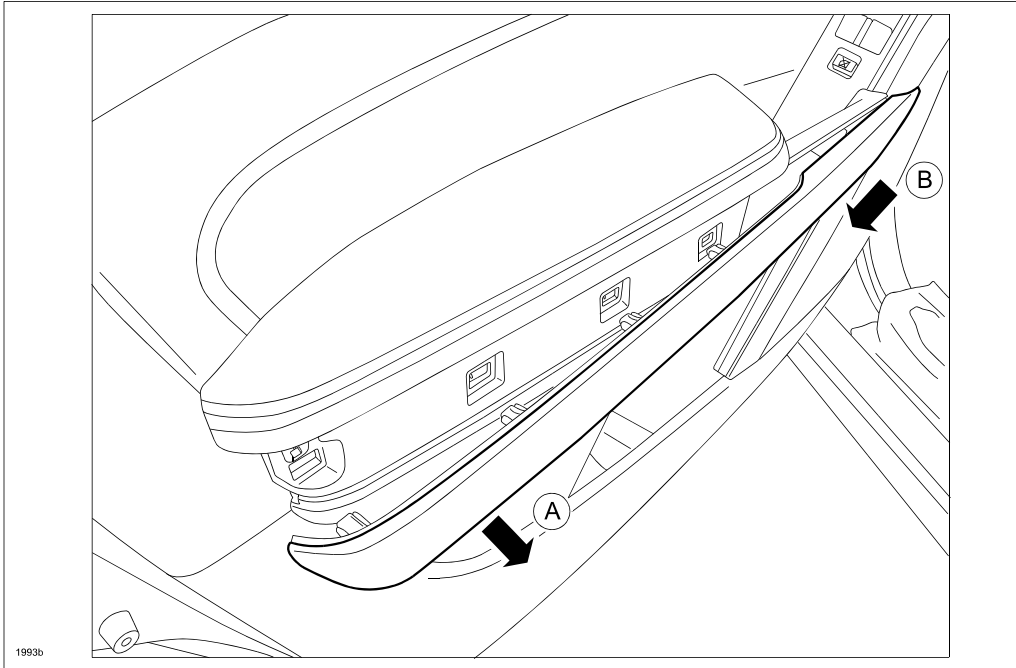

3. Verify repair.

PART(S) INFORMATION

| Part Number | Description | Qty. | Notes |
|--------------|-------------|------|--------|
| TD14-68-43YF | Garnish RF | 1 | Silver |
| TD14-68-46YF | Garnish LF | 1 | Silver |
| TD14-68-53YA | Garnish RR | 1 | Silver |
| TD14-68-56YA | Garnish LR | 1 | Silver |

WARRANTY INFORMATION

NOTE:

- This warranty information applies only to verified customer complaints on vehicles eligible for warranty repair.
- This repair will be covered under Mazda's New Vehicle Limited Warranty term.
- Additional diagnostic time cannot be claimed for this repair.

| | |
|---------------------------------|-------------------------|
| Warranty Type | A |
| Symptom Code | 45 |
| Damage Code | 9D |
| Part Number Main Cause | SEE PART(S) INFORMATION |
| Quantity | 1 |
| Operation Number / Labor Hours: | XXD3PXRX / 0.2 Hrs |